

TR95 Treadmill
General Assembly

TR95-0100-35
S/N HTO100000

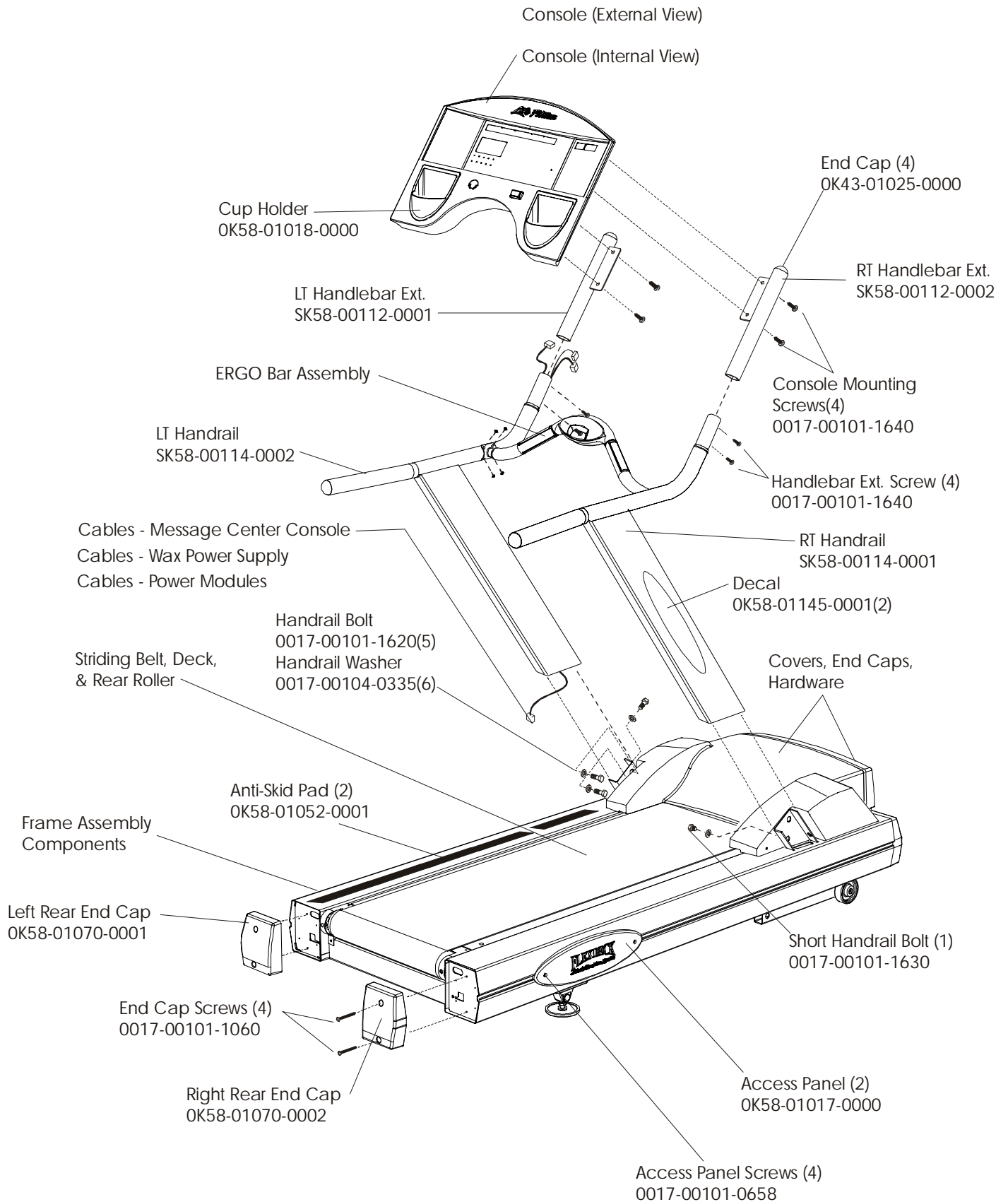

TR95 Treadmill Frame Assembly Components

TR95-0100-35
S/N HTO100000

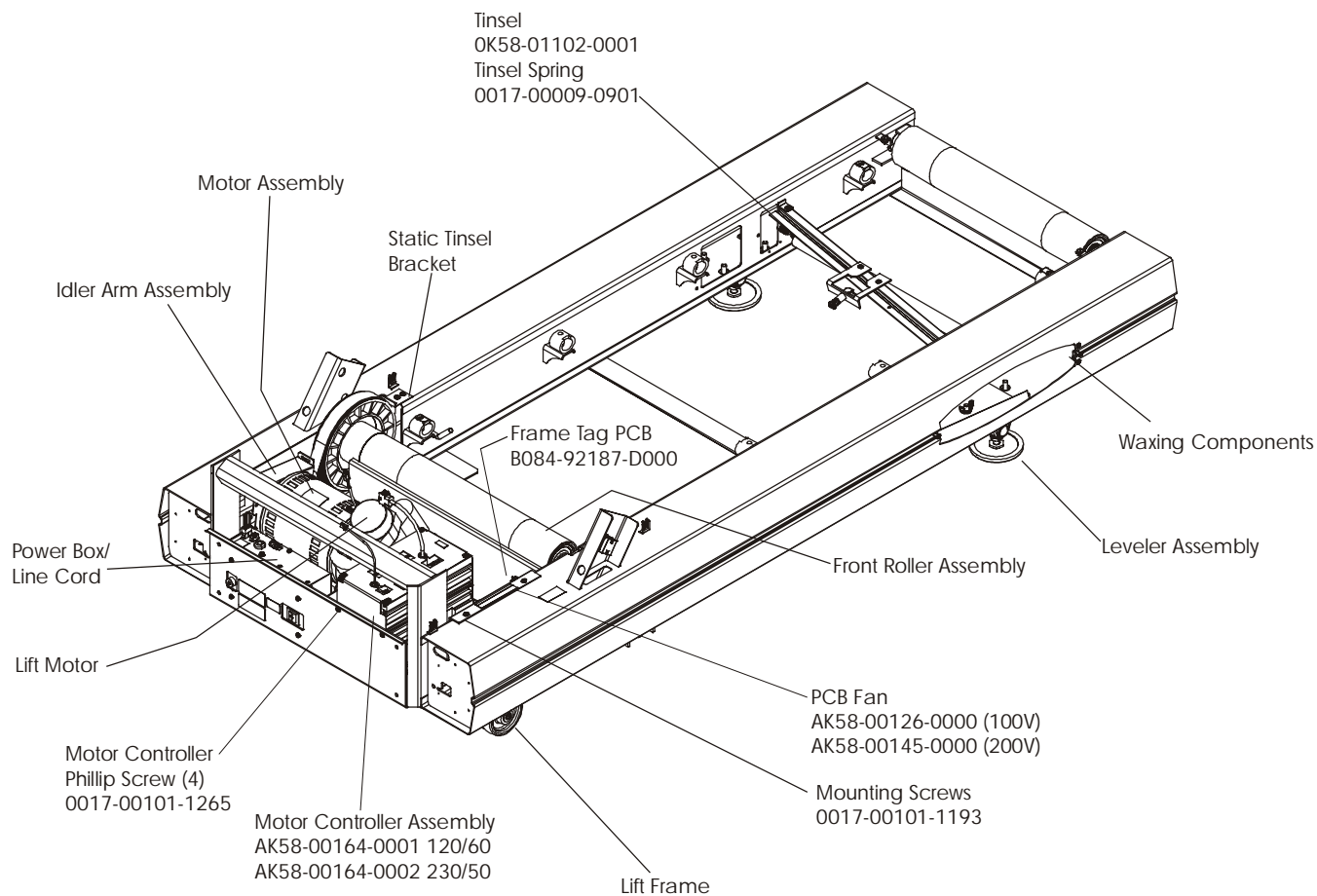

**TR95 Treadmill
Console (External View)**

**TR95-0100-35
S/N HTO100000**

- Console Assembly
- AK58-00056-0001 Eng/Met
- AK58-00056-0003 Ger/Met
- AK58-00056-0004 Spn/Met/Eur (120v/60Hz)
- AK58-00056-0005 Frn/Met (230v/50Hz)
- AK58-00056-0006 Jap/Met
- AK58-00056-0007 Frn/Met/Eur (120v/60Hz)
- AK58-00056-0008 Itl/Met
- AK58-00056-0009 Dut/Met
- AK58-00056-0010 Por/Met
- AK58-00056-0011 Frn/Met (230v/50Hz)

- Workout Profiles
- OK58-01214-0001 Eng/Met
- OK58-01214-0003 Ger/Met
- OK58-01214-0004 Spn/Met/Eur
- OK58-01214-0006 Jap/Met
- OK58-01214-0007 Frn/Met/Eur
- OK58-01214-0008 Itl/Met
- OK58-01214-0009 Dut/Met
- OK58-01214-0010 Por/Met

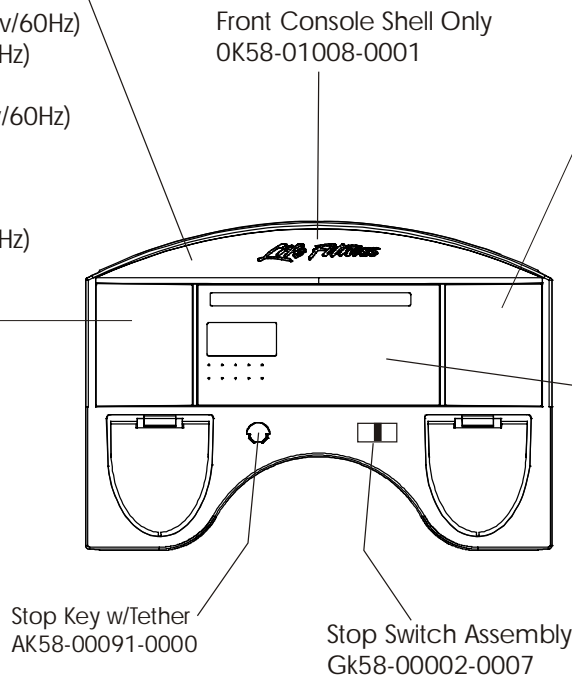

- Zone Training Overlay
- OK58-01213-0001 Eng/Met
- OK58-01213-0003 Ger/Met
- OK58-01213-0004 Spn/Met/Eur
- OK58-01213-0006 Jap/Met
- OK58-01213-0007 Frn/Met/Eur
- OK58-01213-0008 Itl/Met
- OK58-01213-0009 Por/Met
- OK58-01213-0010 Dut/Met

- Tray/Switch w/Overlay Assy
- AK58-00160-0001 Eng/Met
- AK58-00160-0003 Ger/Met
- AK58-00160-0004 Spn/Met/Eur
- AK58-00160-0006 Jap/Met
- AK58-00160-0007 Frn/Met/Eur
- AK58-00160-0008 Itl/Met
- AK58-00160-0009 Dut/Met
- AK58-00160-0010 Por/Met

- Rear Console Decal
OK58-01129-0000

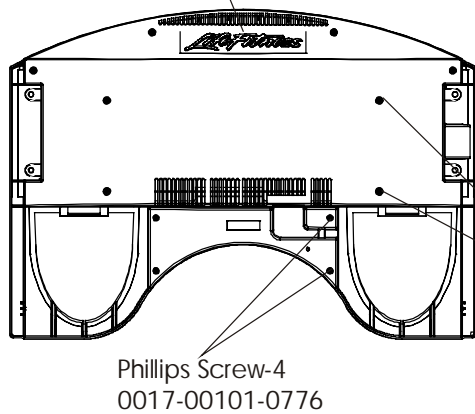

- Rear Console
OK58-01009-0000

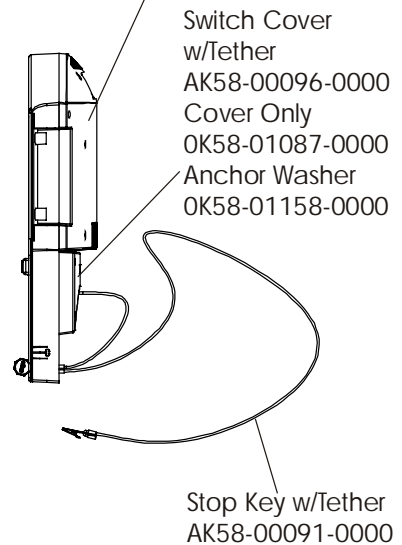

**TR95 Treadmill
Console (Internal View)**

**TR95-0100-35
S/N HTO100000**

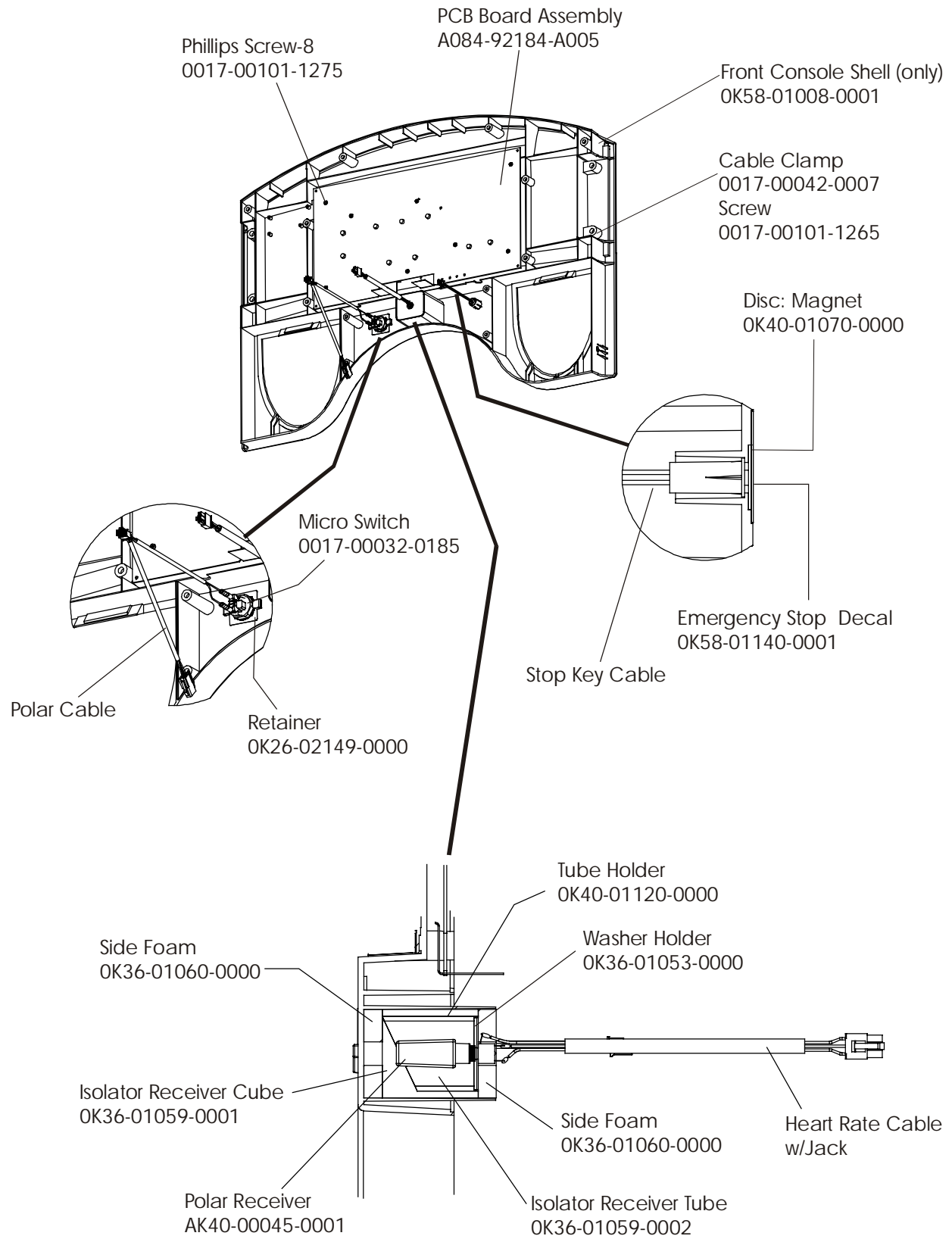

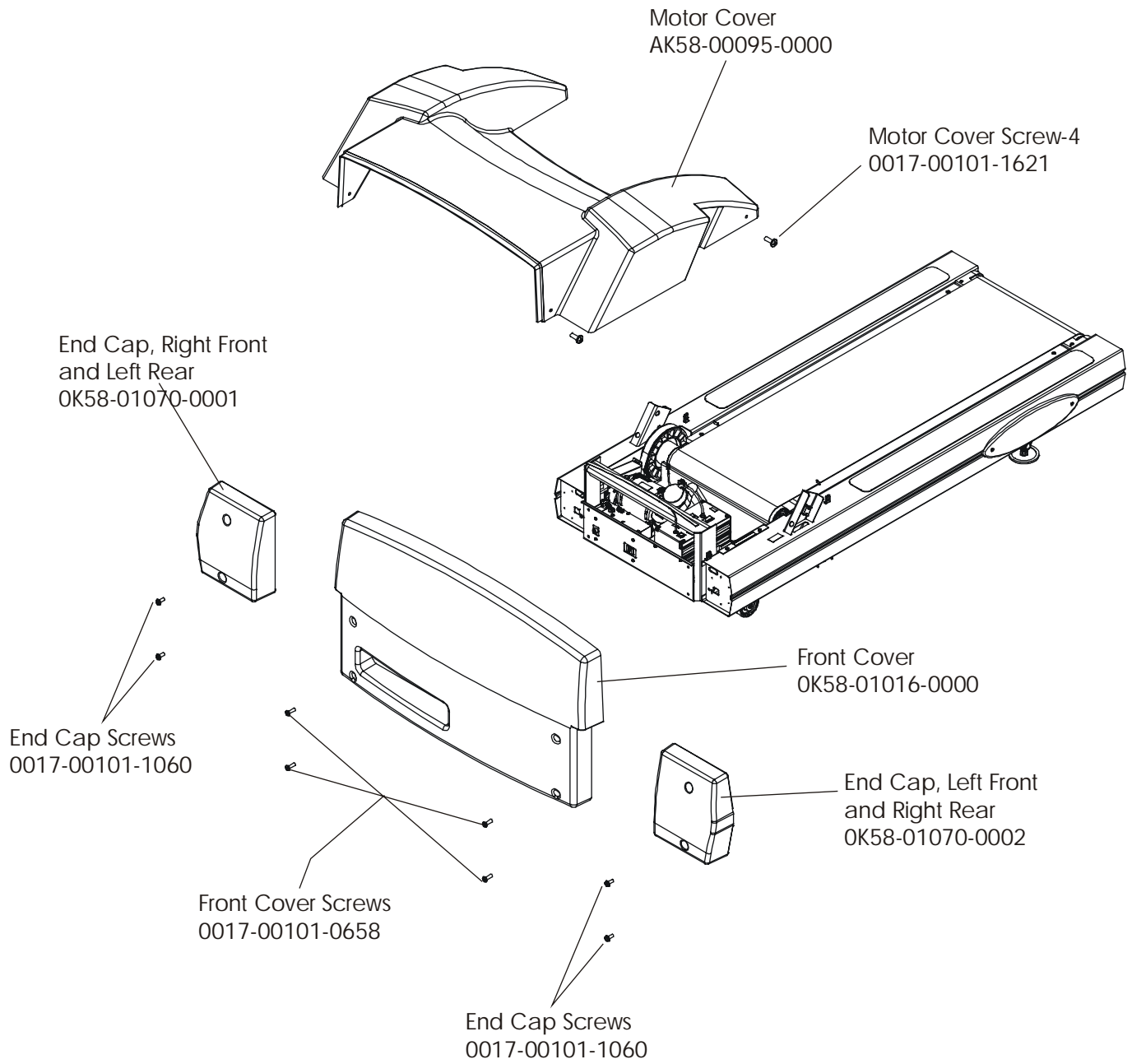

**TR95 Treadmill
Belt, Dek, Rear Roller**

**TR95-0100-35
S/N HTO100000**

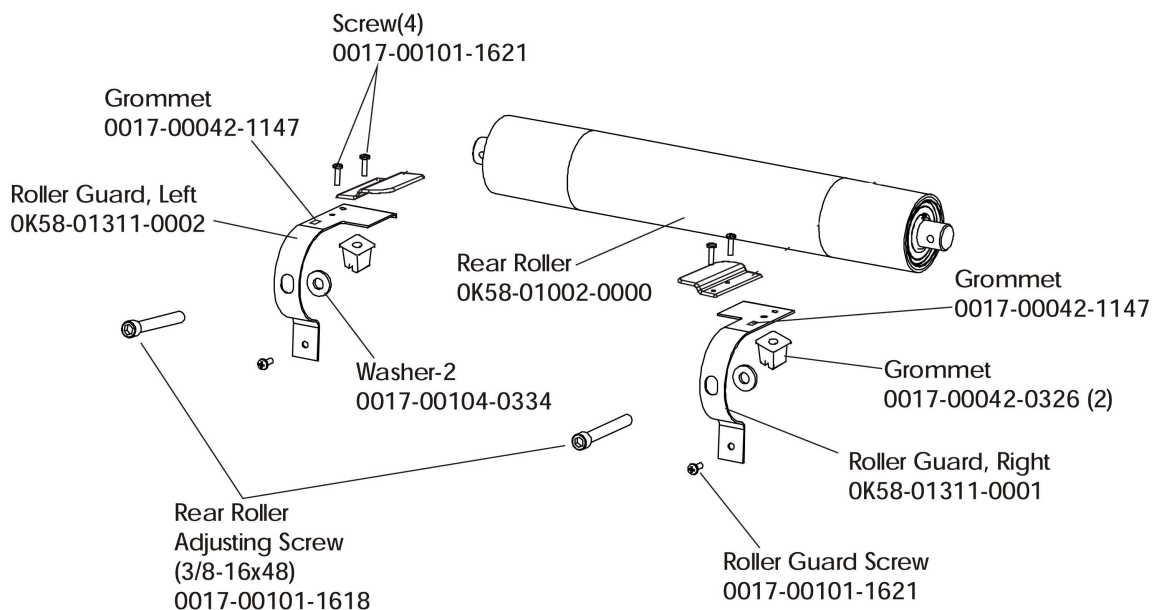
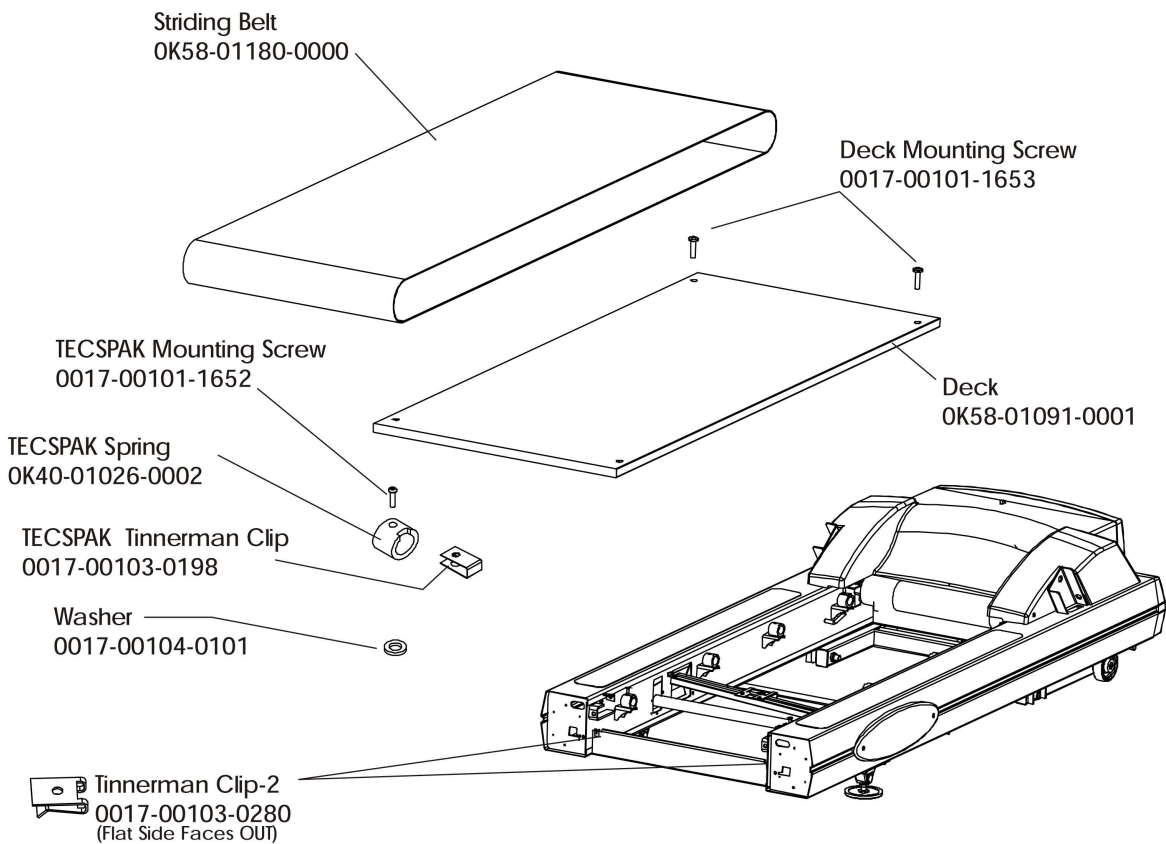

IMPORTANT: Components can be ordered separately with Serial Numbers above:
 TR9100 HTN102105-Above, TR9500 HTM105585-Above, and TR9700 HTP100531-Above.
 Use the appropriate Roller Guard Kit: GK58-00002-0056 for TR91/95, and GK58-00002-0057 for Tr97 with
 Serial Numbers: TR9100 HTN102105-Below, TR9500 HTM105585-Below, and TR9700 HTP100531-Below.

TR95 Treadmill
Lift Motor and Lift Frame

TR95-0100-35
S/N HTO100000

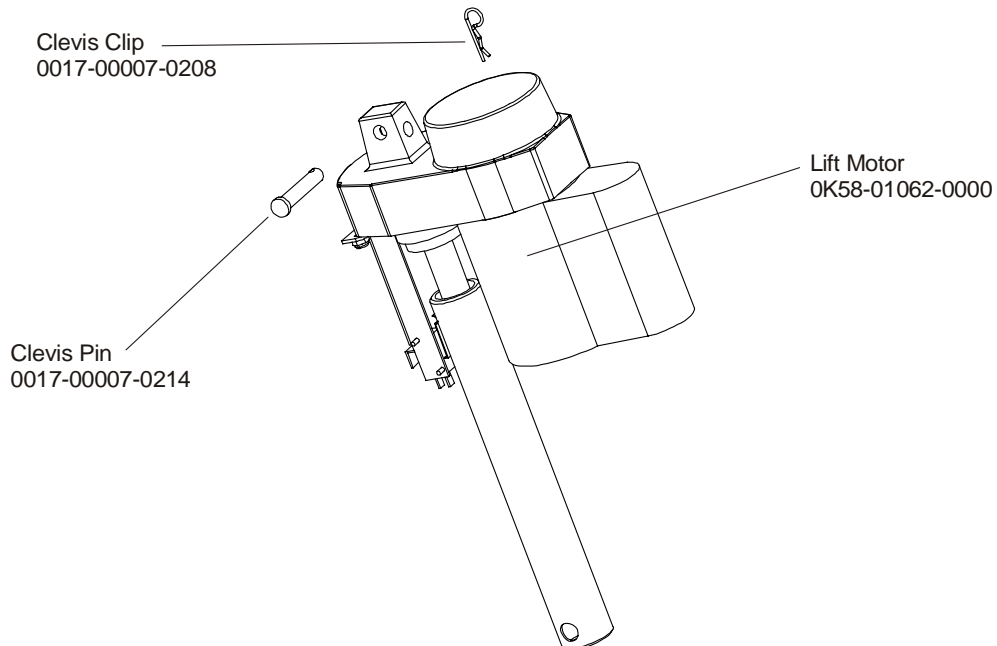
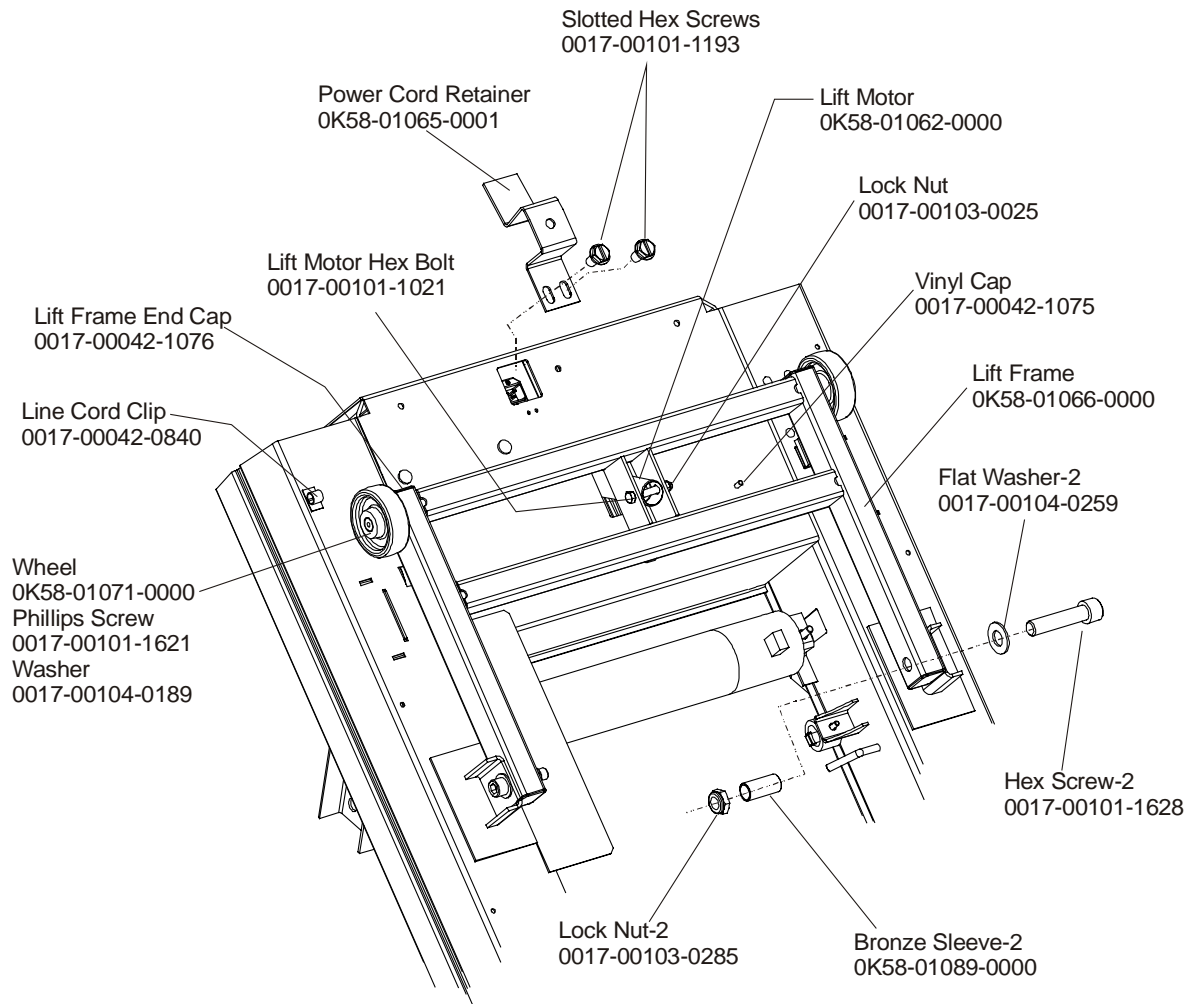

**TR95 Treadmill
Power Box Assembly**

**TR95-0100-35
S/N HTO100000**

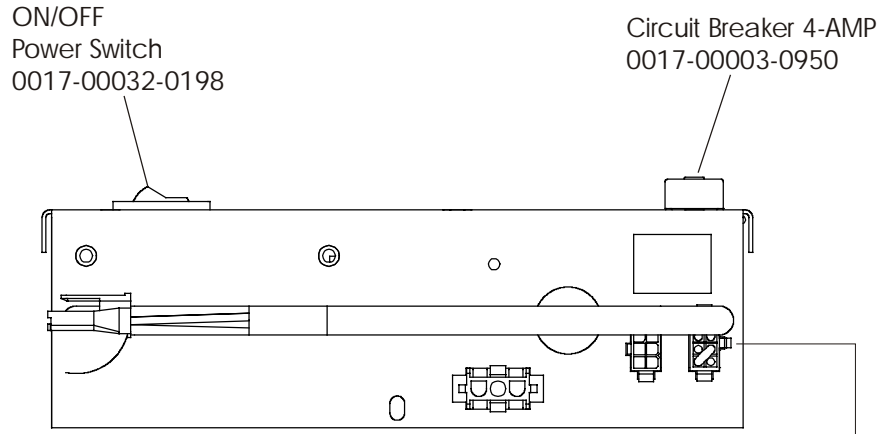

TOP VIEW

Transformer (EURO Only)
0017-00003-0905

Phillips Pan Head Screw
0017-00101-0162

Phillips Pan Head Screw
0017-00101-1182

Transformer Bracket
OK58-00120-0004

Jumper Line
AK58-00120-0004 - 240V
AK58-00120-0003 - 230V
AK58-00120-0002 - 200V
AK58-00120-0001 - 100V
AK58-00120-0000 - 120V

Power Box Assembly
AK58-00176-0000 - 120V
AK58-00183-0001 - 100V
AK58-00183-0002 - 230-240V/50Hz
AK58-00183-0003 - 200V
AK58-00183-0004 - 220V/60Hz
AK58-00183-0005 - 240V+ Continental

Line Cord (Plug End Changes)
0017-00003-0947 12' 120v Line Cord
0017-00003-0923 Domestic
0017-00003-0948 12' 220v Line Cord
0017-00003-0915 RT Angle Plug
0017-00003-0781 220v/60Hz
0017-00003-0696 Continental
0017-00003-0890 UK

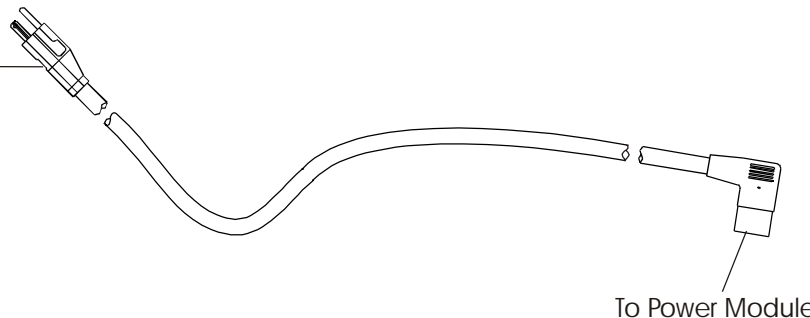

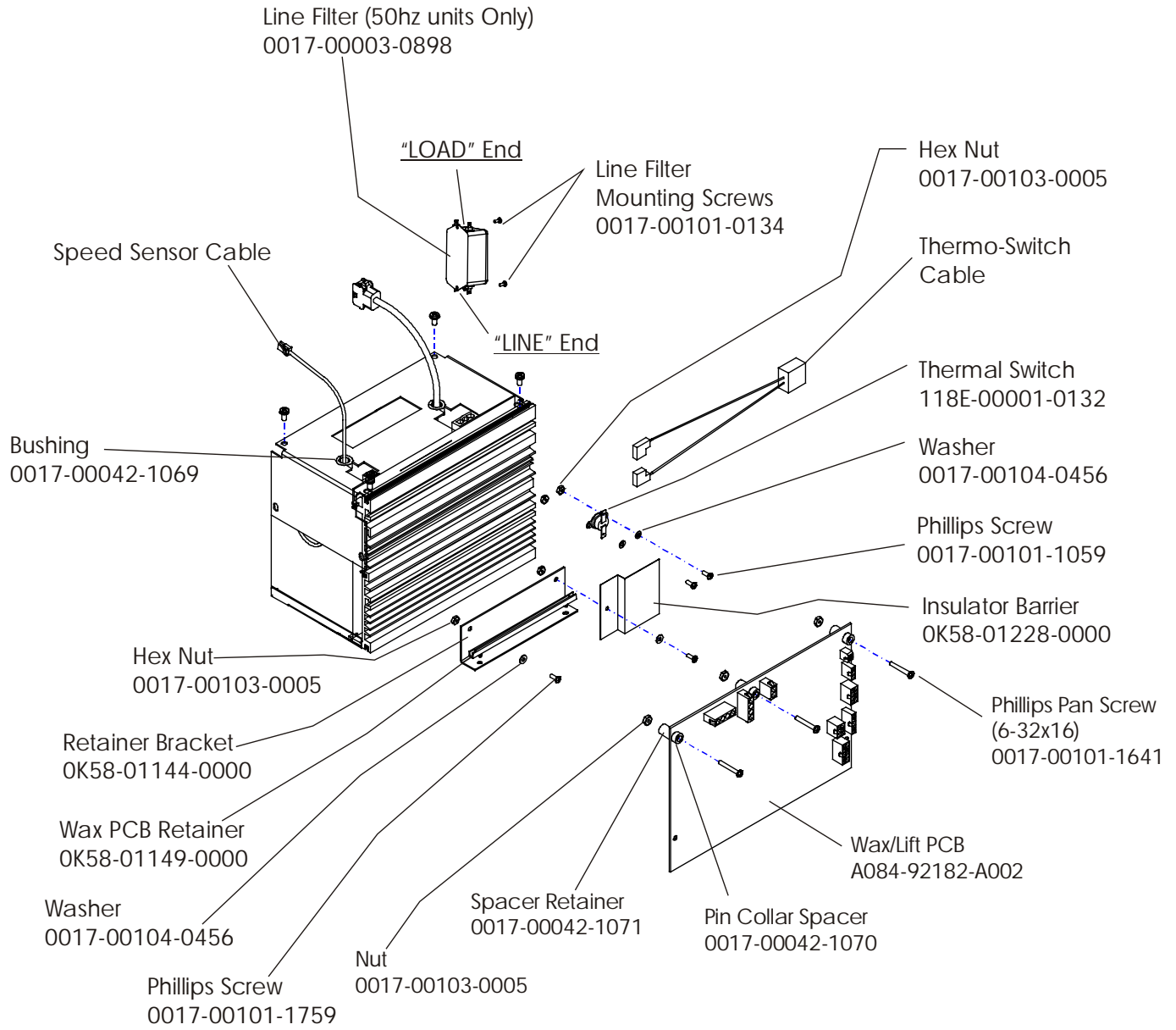

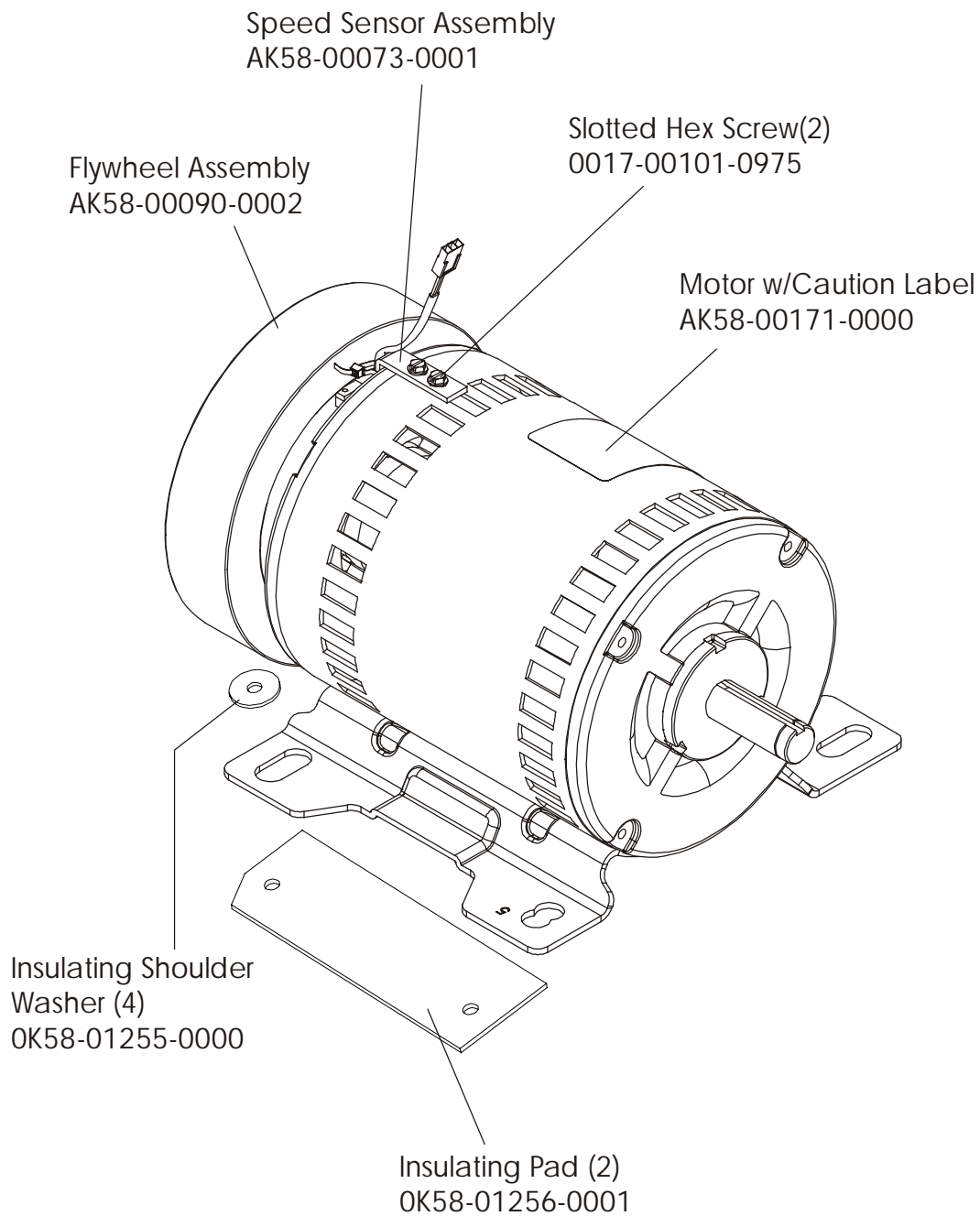

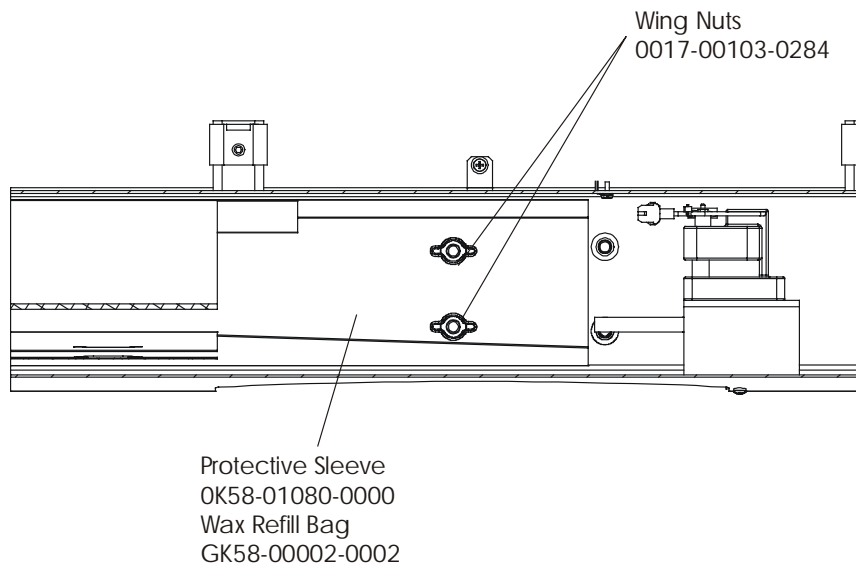
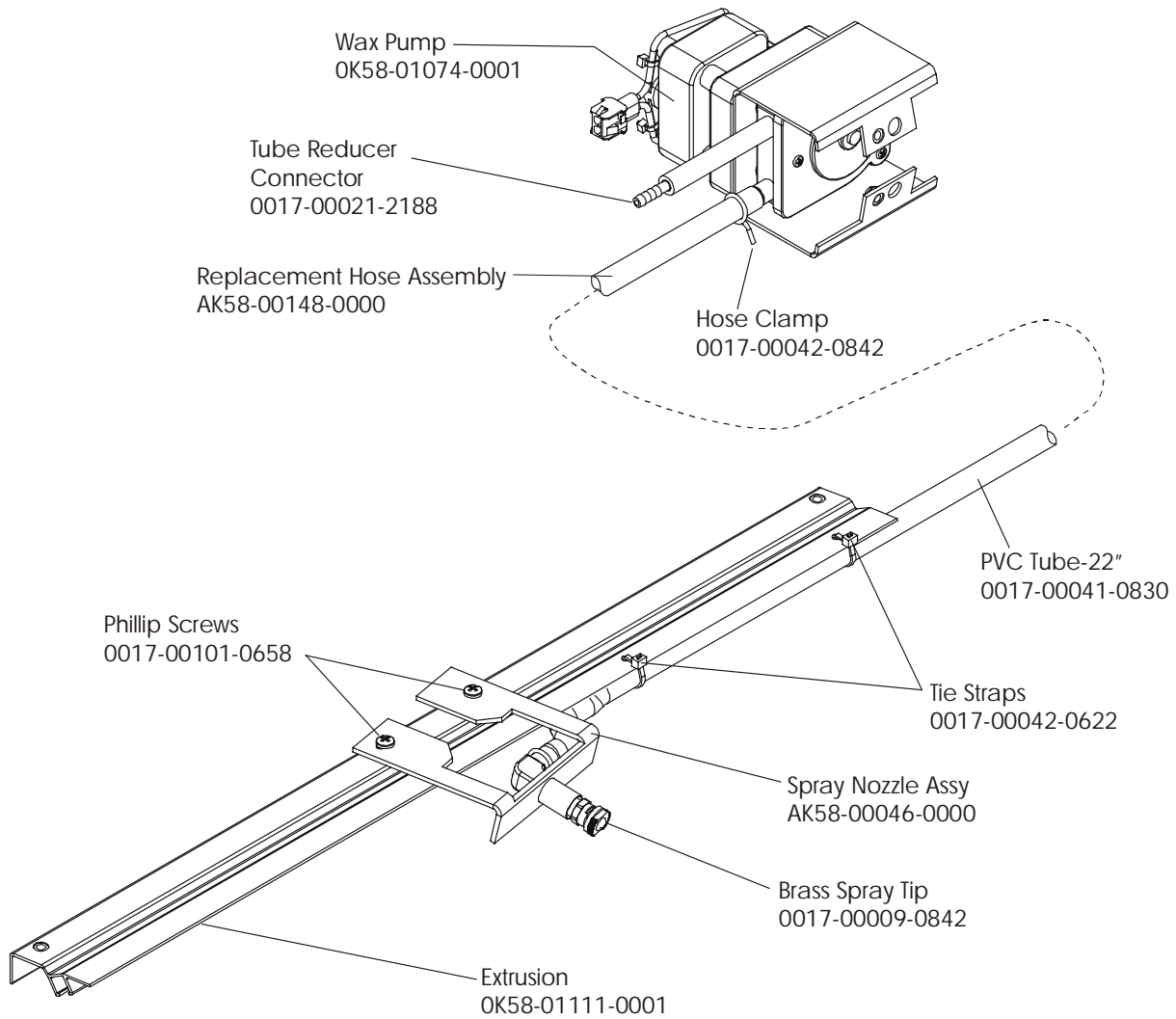

**TR95 Treadmill
Idler Arm Assembly**

**TR95-0100-35
S/N HTO100000**

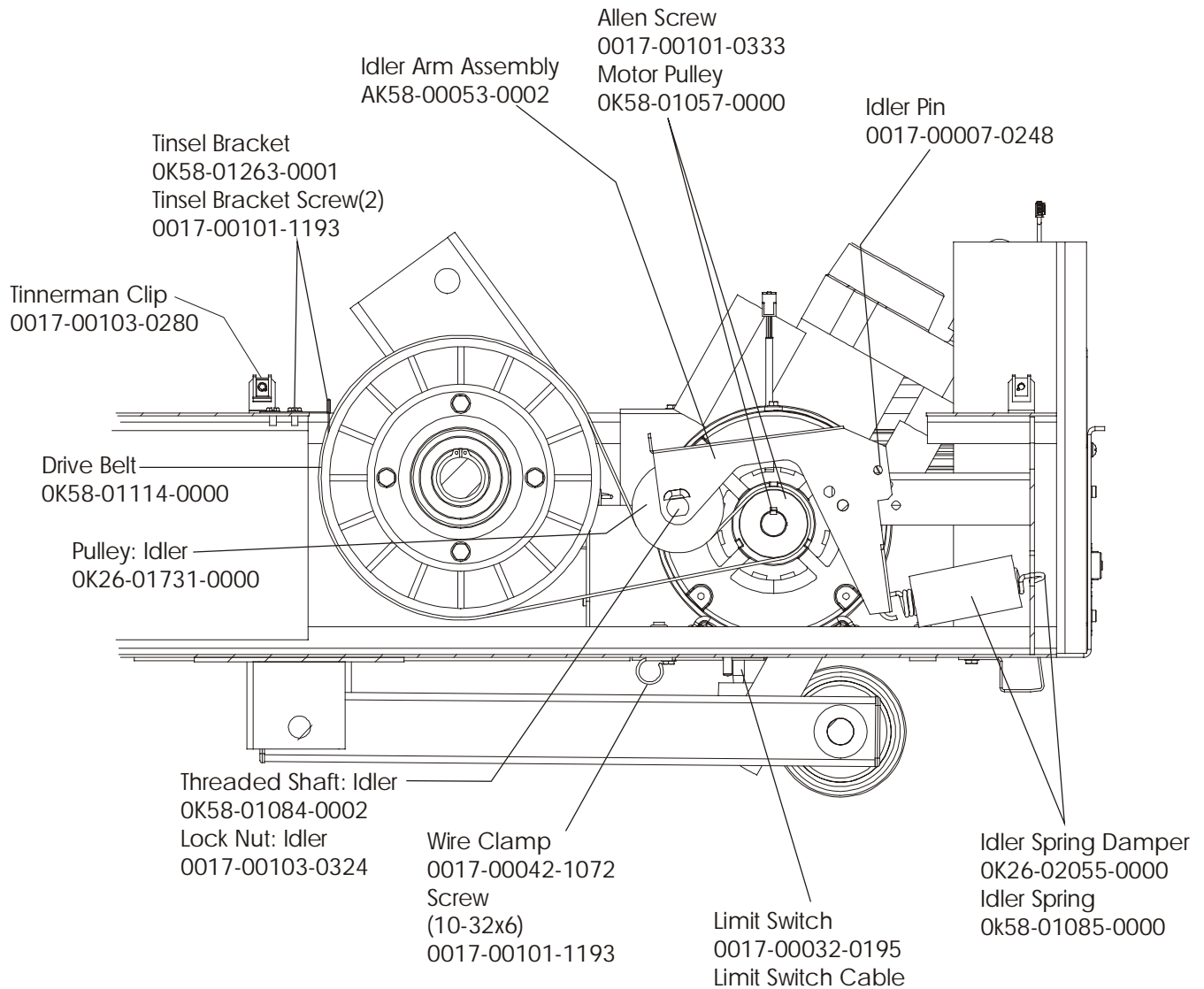

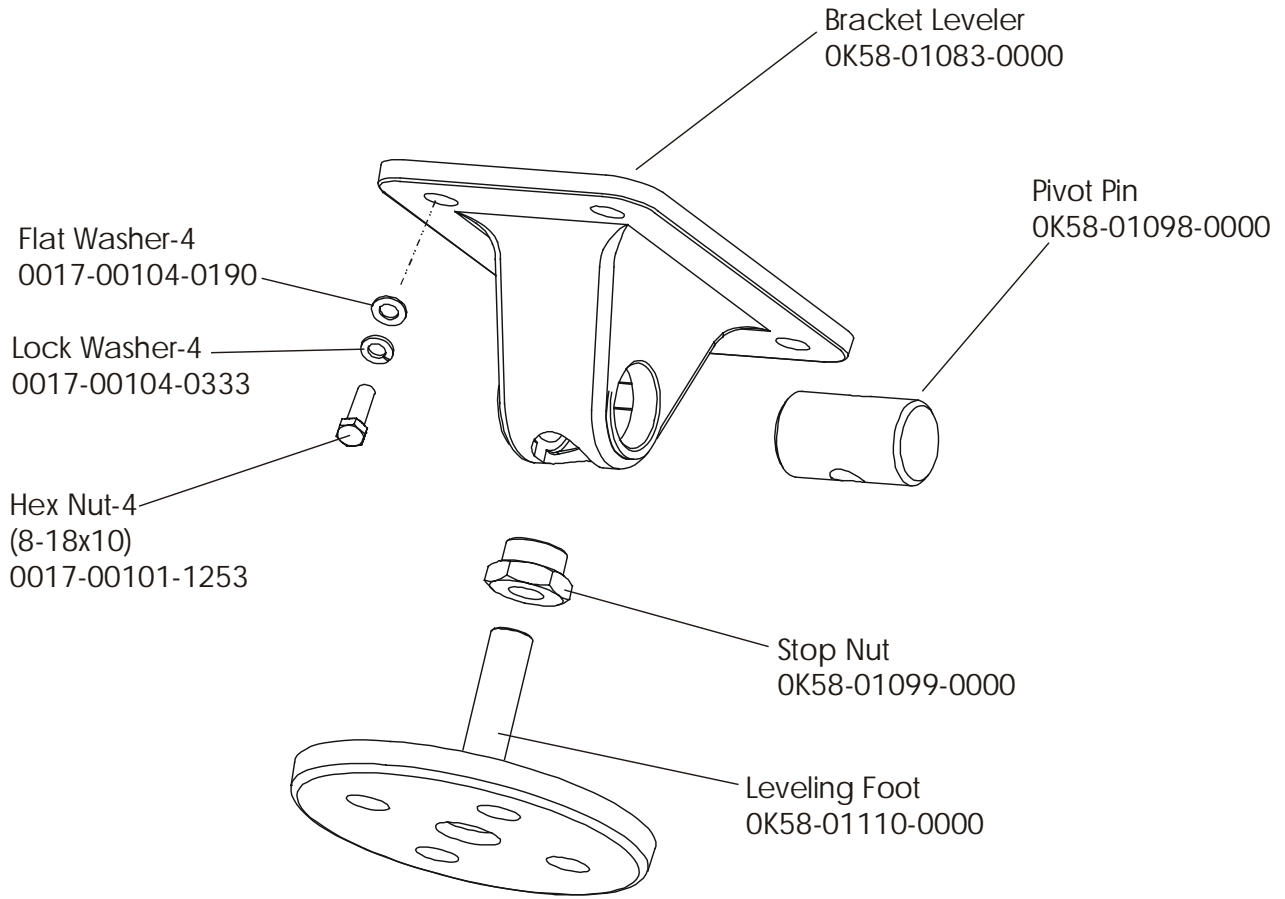

TR95 Treadmill
Front Roller Assembly – AK58-00066-0000

TR95-0100-35
S/N HTO100000

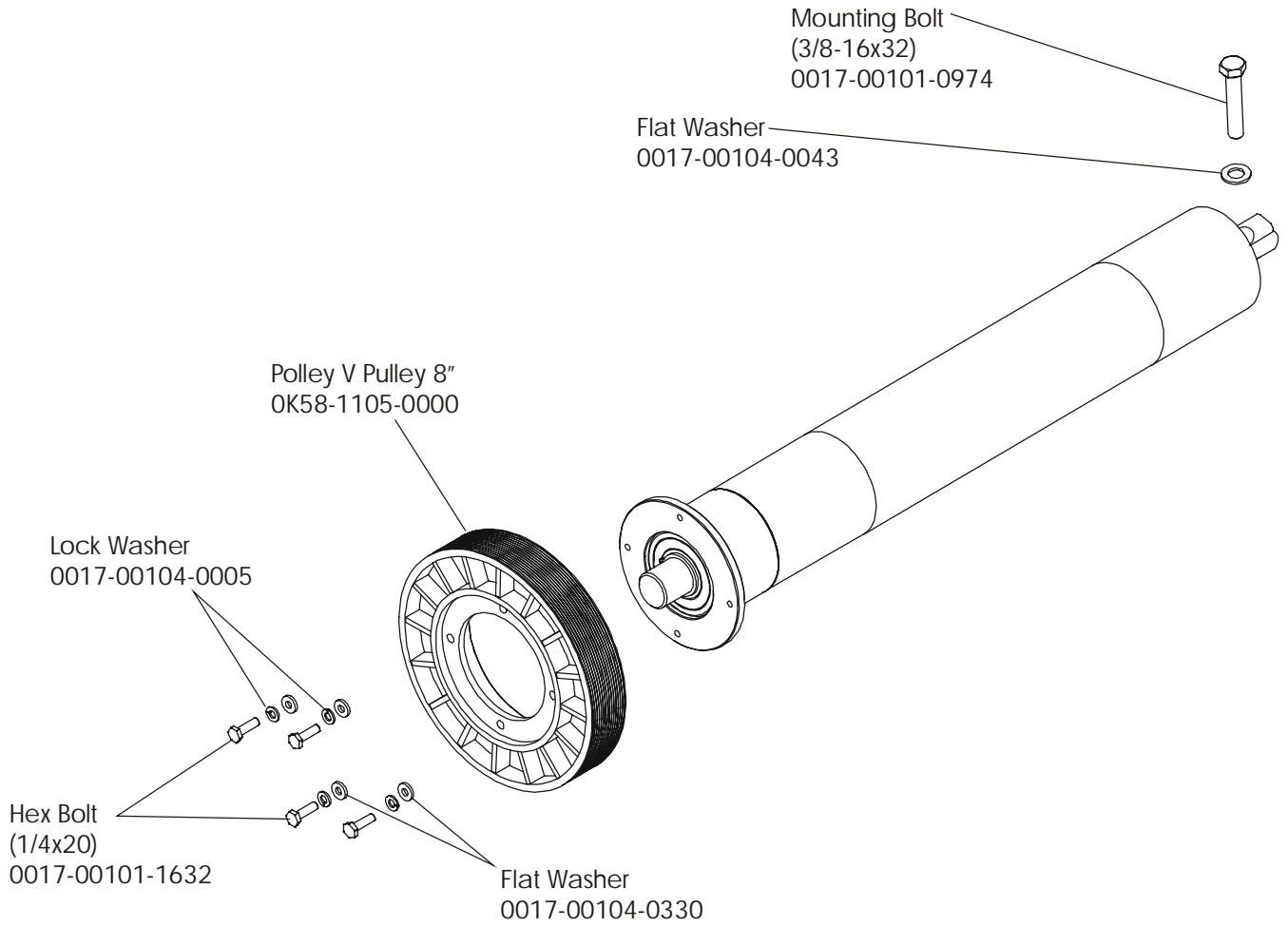

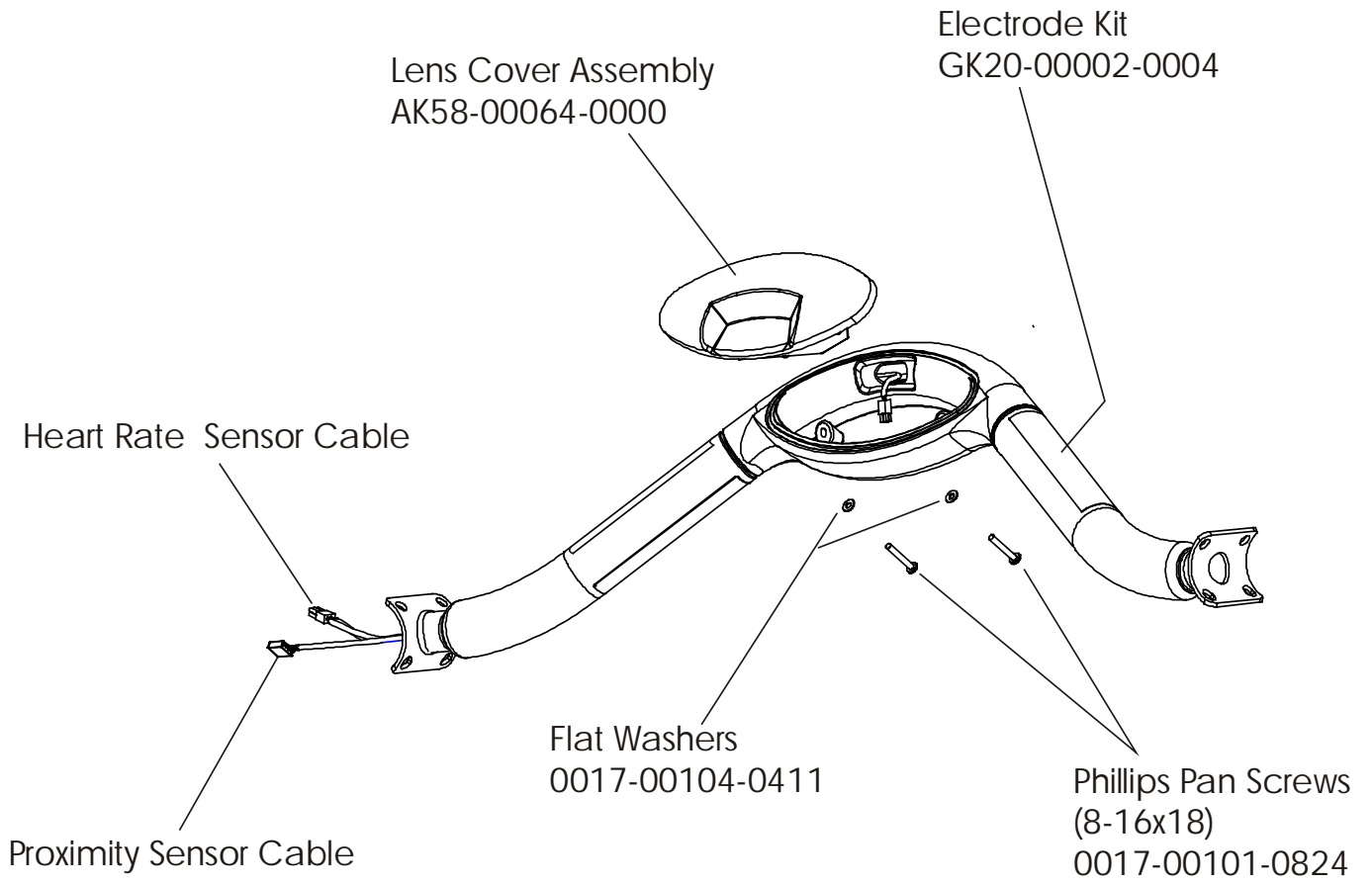

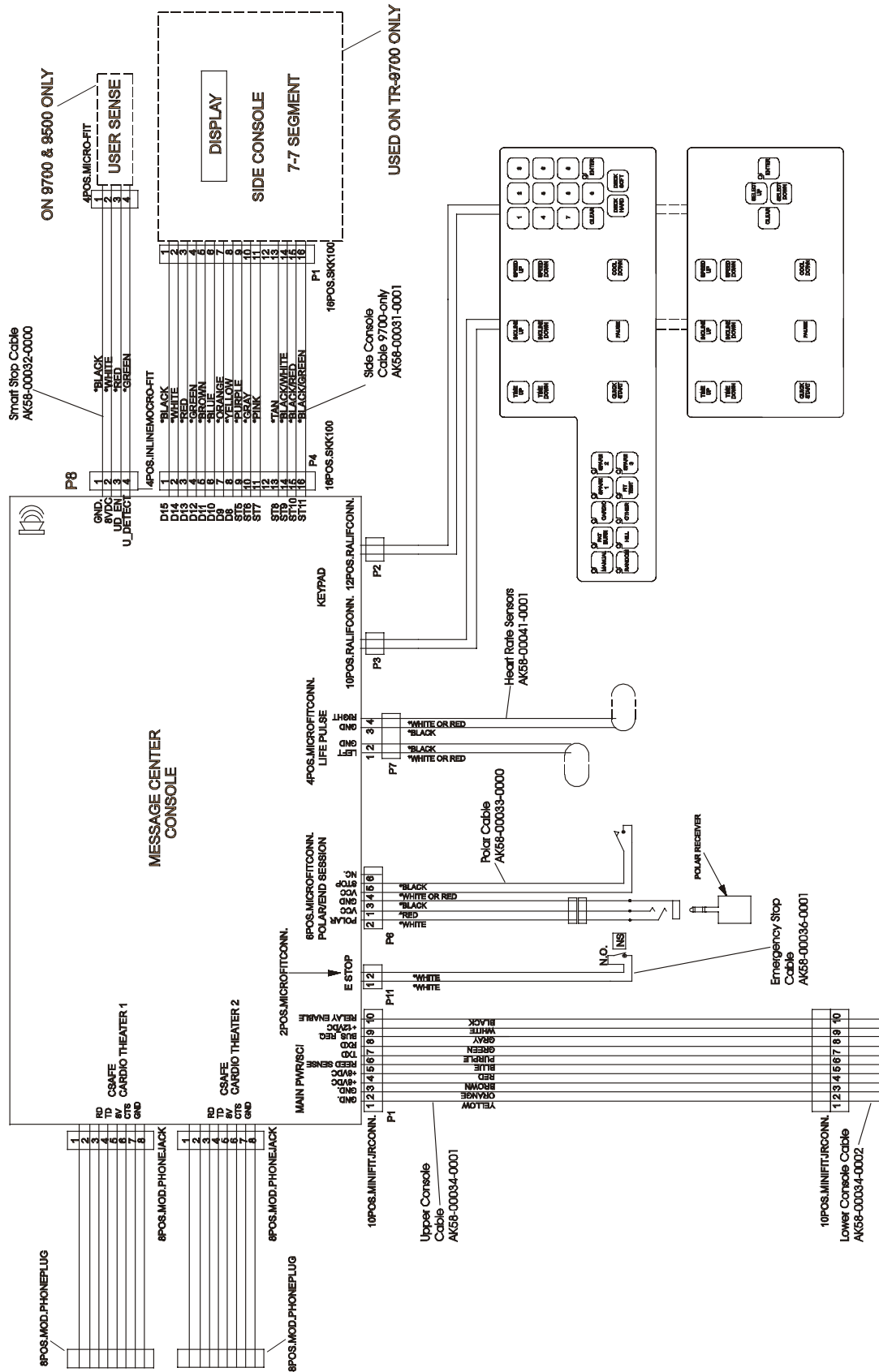

Message Center Console

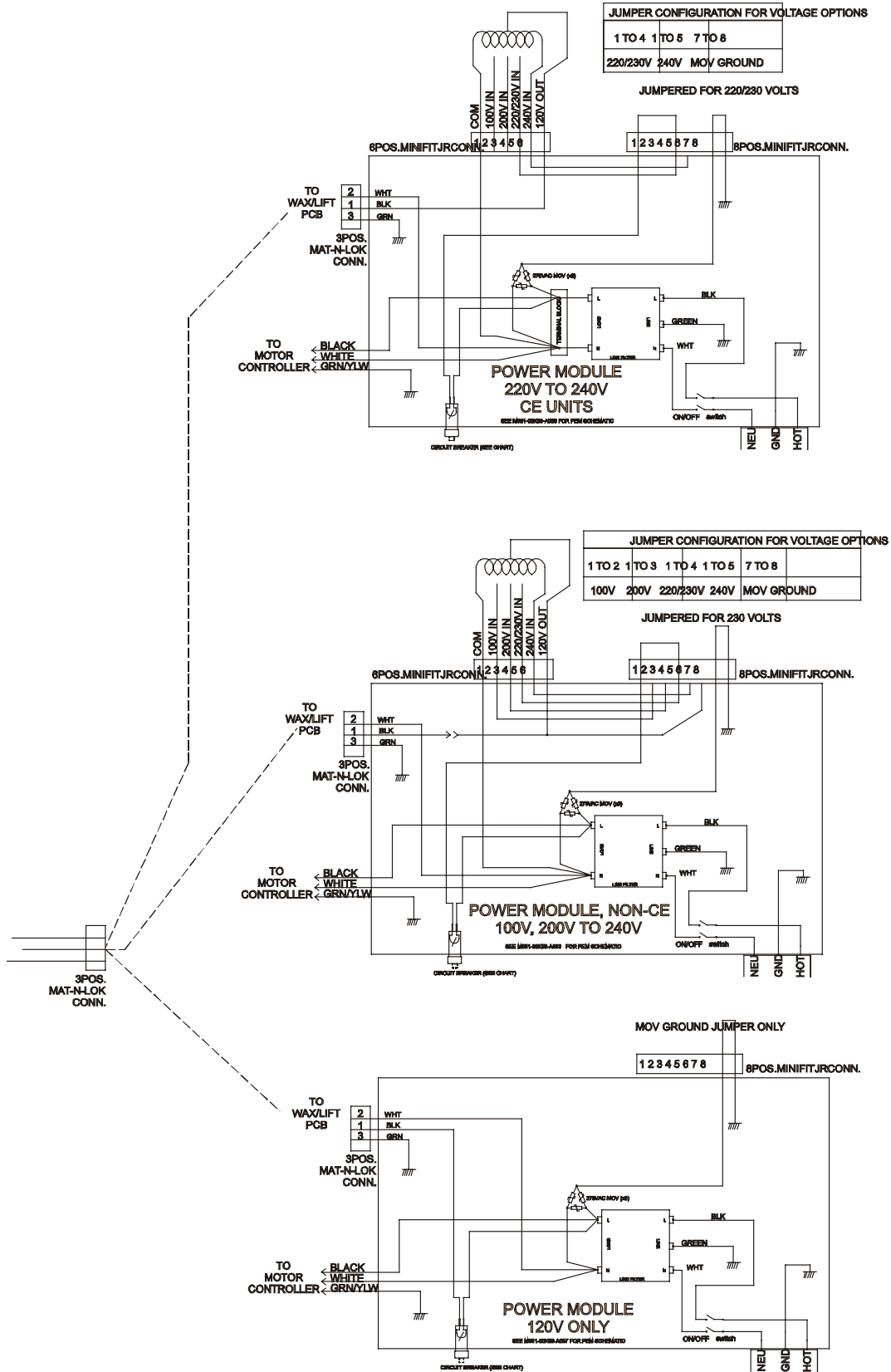

Power Modules